

High-Performance Curved Crystal Monochromator

To meet the increasing demand for hard x-rays posed by protein crystallography research, a superconducting wiggler (SW6) has been installed in the Taiwan Light Source (TLS) ring of NSRRC to provide high intensity photons up to 20 keV. Three beamlines were designed to fully utilize the radiation fan from the output of the SW6. A double crystal monochromator (DCM) beamline (BL13B) receives the central radiation fan of the wiggler output, and two asymmetric-cut, curved crystal monochromator (ACCM) beamlines (BL13A and BL13C) receive the sideways output. Each of the two side-branch beamlines has a Rh-coated, Si-substrate vertical focusing mirror followed by a curved Si(111) crystal monochromator, the latter also functioning as the horizontal focusing element. While the two side-branch beamlines are designed for fixed-energy experiments, the capability of energy scan from 12 keV to 14 keV is provided by a novel curved crystal monochromator. The device incorporates efficient cooling and high-precision bending mechanisms and will be the subject of discussion of this article.

The curved crystal monochromator is often used in x-ray beamlines for its reasonably good energy resolution and focusing properties. By combining this type of monochromator with a focusing mirror, a branch beamline can be added within a tight space around the central beamline. Unlike DCM beamlines, this type of beamline is not designed primarily for applications that requires scanning a wide range of photon energy, though energy scan within a few keV can be facilitated by changing the Bragg angle and adjusting the radius of curvature of the crystal, as is the case here. In our design, the water-cooled Rh vertical focusing mirror is positioned upstream of the monochromator to simplify the energy scanning mechanism, and to reduce the heat load on the crystal.

The curved crystal monochromator plays a critical role in determining the ultimate performance of such a side-branch beamline, as it has to maintain good energy resolution and focusing properties while sustaining high heat load. The design of monochromator should combine efficient cooling and bending mechanisms in a compact unit that allows precise adjustment on a goniometer assembly. However, the design criteria for cooling

and bending mechanisms are not easily met at the same time, especially for the type of monochromator that requires bending a flat crystal to radius less than 60 m. For example, the bender mechanism should provide pure bending of the crystal and minimize deformation of the diffraction lattice, but efficient cooling requires circulation of the coolant close to the diffracting surface and the pressure of the coolant could distort the lattice, such as the case of internally cooled crystal bender. In addition, this type of crystal bender suffers from displacement of the crystal center normal to the beam direction when the crystal radius is changed. The other commonly used type of curved crystal monochromator is the triangular-shaped crystal bender. This design has the advantage of preventing the crystal from being twisted during bending, but it also suffers from the aforementioned center displacement, and to a larger degree because only the tip is bent relative to the triangle base. The thin triangular crystal plate is often cooled by conduction through the crystal itself or by partially immersing the crystal in the Ga/In eutectic, but in either case the cooling is not sufficient to bring a uniform temperature gradient across the diffraction plane.

To address the above design considerations and to provide a cost-effective solution, we designed a water-cooled crystal bender with improved cooling efficiency and bending precision over some of the existing designs, as shown in Fig. 1. Our design features a piezo-driven bender that minimizes the center displacement described above, and employs a large cooling area directly under the beam footprint for efficient heat transfer. Basically, the design employs a 2mm thick silicon single crystal plate mounted and suspended by clamping at its two ends on a water-cooled copper block, which is brazed to a stainless steel bending structure driven symmetrically by two piezo actuators. The stainless steel structure adds rigidity to and prevents twisting of the bender, and provides the necessary elasticity during bending. The structure also functions as the mounting base, and its resistance to deform with temperature change enhances the stability of the whole bender. The gap between the silicon plate and the copper block is 300 μm and is filled with Ga/In eutectic.

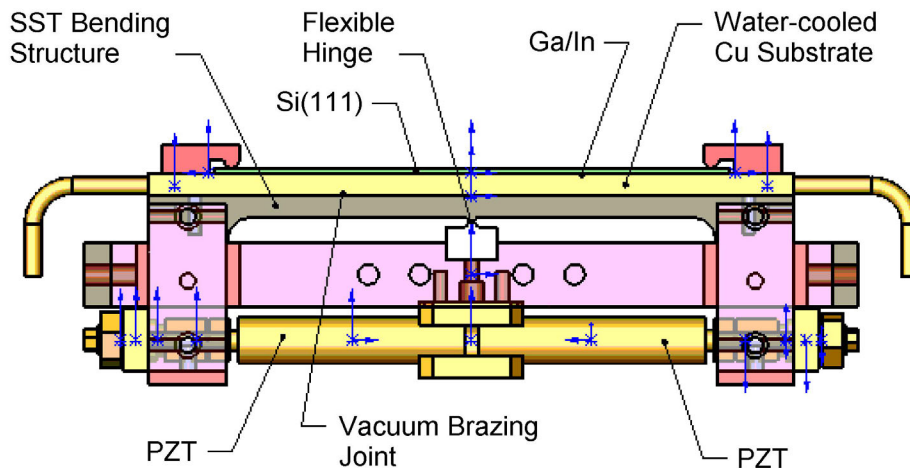

Fig. 1: The bender and cooling mechanism of the curved crystal monochromator.

A flexible hinge extended from the center of the stainless steel plate is bolted to a center piece also made of the same material. This center piece defines the mounting reference of the bender and is bolted to an interface piece on the goniometer. Two piezoelectric actuators, mounted at their bases symmetrically with respect to the center line defined by the flexible hinge, are also bolted to the center piece, as can be seen below the hinge in Fig. 1. The tip of each piezo actuator touches one leg of the bending steel structure by a ball joint, thus providing the necessary extrusion for deforming the steel structure.

If we look at the surface of the steel and the copper plates when they are deformed by the piezo actuators, the center hinge of the steel plate is fixed, while its edges are raised. Since we clamped the crystal plate only at its two edges to the copper plate, the edge rise of the copper plate successfully provides a "pure bending" of the crystal plate. Moreover, the fixed flexure hinge serves the important function of keeping the center of the crystal plate fixed in the direction normal to the crystal surface. This is in contrast to the more commonly seen bending situation where the center of the bending plane is recessed. This is also an improvement over the typical triangular crystal monochromator where only one edge is displaced to provide change of radius. In our design, the center of the crystal undergoes negligible displacement in the normal direction when the crystal radius is varied during bending. The actual displacements measured as the radius is changed from 48 m to 56 m for BL13A, and from 66 m to 78 m for BL13C, are

both less than 2 μm . Thus the monochromator can continuously scan photon energy from 12 keV to 14 keV without the need to realign the crystal.

The performance of the bender is examined by measuring the radius of curvature of the crystal with a long trace profiler (LTP). We start with a flat crystal plate of 2mm thickness and pre-bend the crystal using screws to approach the desired range of radius. The precision bending to target radius is provided by the two symmetrically mounted piezoelectric actuators, which are equipped with position sensors to display the exact displacement at the tip of the actuator, and therefore allow reproducible bending to any radius in the above range. Although the slope error at the target radius is larger than the intrinsic slope error of the flat crystal, it is still reasonably small for the application of x-ray diffraction. Table 1 shows the slope errors measured at various bending radii for a 120 mm section on the 200 mm long crystal plate, on which the photon beam footprint is 80 mm by 3 mm. As can be seen in the table, the slope error varies little over the entire bending range. The line profile and slope error measured across the center line of the crystal

Table 1 The crystal radius and slope error measured by an LTP at different bender settings.

	Radius (m)	Slope error (μrad)
before bending	104.3	16.3
R1	68.9	19.0
R2	58.7	19.7
R3	45.2	20.5
R4	30.2	21.0

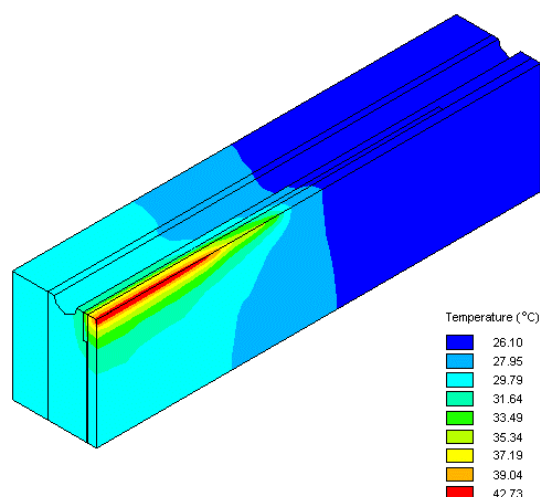

Fig. 2: The simulated temperature distribution of crystal and cooling substrate.

in the transverse direction also change very little, indicating a high performance bending mechanism with minimum twisting.

The cooling mechanism of our curved crystal monochromator employs an indirect-cooling method. As described in the previous paragraph, the crystal plate is clamped at its two short edges on the copper plate, which has a 300 μm recess below the crystal. Therefore there is no direct contact between the crystal plate and the Cu substrate except where the crystal plate is clamped, and it remains so during bending. The space between the crystal plate and Cu substrate established by the recess is filled by thermally conductive Ga/In eutectic. The copper is nickel-plated to minimize alloy formation with Ga, and is grooved at the center area to help retain Ga/In in position. The 300 μm gap is small enough such that the Ga/In adheres to both surfaces of the crystal and copper plate without migrating or dribbling. It also adapts itself to the deformation of crystal plate and Cu substrate during bending, without exerting undue force on the crystal surface. Stop-off materials are deposited around the edges of the crystal and copper to further limit any migration of the alloy. To remove heat load from the crystal, the copper plate has one water channel drilled below the footprint of synchrotron beam. Fig. 2 shows a simulation of the crystal under 100 W heat load in a one-quarter cross section view of the temperature distribution of the crystal and substrate. The temperature gradient is much less than that obtained using other types of indirect cooling method.

In summary, we have designed an innovative crystal bender for use in the curved crystal mono-

chromator that provides an energy tuning range from 12 keV to 14 keV. The design features a high-precision bending mechanism that minimizes center displacement during bending and offers a large range of bending radius, and an effective indirect cooling mechanism that provides uniform and efficient heat transfer. The performance of the side-branch beamline will be enhanced by this new design with improved efficiency and stability.

AUTHORS

C. H. Chang, C. I. Ma, L. J. Huang, J. Y. Yuh, and K. L. Tsang
National Synchrotron Radiation Research Center,
Hsinchu, Taiwan

PUBLICATIONS

- P. C. Tseng, Y. C. Jean, C. H. Chang, L. J. Huang, H. S. Fung, Y. F. Song, C. I. Ma, Y. S. Huang, F. Chao, C. J. Chen, and K. L. Tsang, SRRC/RBM/IM/02-04, Apr. 26, 2002.
- C. I. Ma, C. H. Chang, L. J. Huang, C. C. Chen, P. C. Tseng, H. S. Fung, S. C. Chung, S. Y. Perng, D. J. Wang, Y. C. Jean, K. L. Tsang, and C. T. Chen, Eighth International Conference on Synchrotron Radiation Instrumentation (SRI 2003).

CONTACT E-MAIL

chchang@nsrrc.org.tw